



Designation: G86 – 17

# Standard Test Method for Determining Ignition Sensitivity of Materials to Mechanical Impact in Ambient Liquid Oxygen and Pressurized Liquid and Gaseous Oxygen Environments<sup>1</sup>

This standard is issued under the fixed designation G86; the number immediately following the designation indicates the year of original adoption or, in the case of revision, the year of last revision. A number in parentheses indicates the year of last reapproval. A superscript epsilon ( $\epsilon$ ) indicates an editorial change since the last revision or reapproval.

## 1. Scope

1.1 This test method<sup>2</sup> describes test equipment and techniques to determine the impact sensitivity of materials in oxygen under two different conditions: (1) in ambient pressure liquid oxygen (LOX) or (2) under pressure-controlled conditions in LOX or gaseous oxygen (GOX). It is applicable to materials for use in LOX or GOX systems at pressures from ambient to 68.9 MPa (0 to 10 000 psig). The test method described herein addresses testing with pure oxygen environments; however, other oxygen-enriched fluids may be substituted throughout this document.

1.2 This test method provides a means for ranking nonmetallic materials as defined in Guide G63 for use in liquid and gaseous oxygen systems and may not be directly applicable to the determination of the sensitivity of the materials in an end-use configuration. This test method may be used to provide batch-to batch acceptance data. This test method may provide a means for evaluating metallic materials in oxygen-enriched atmospheres also; however, Guide G94 should be consulted for preferred testing methods.

1.3 Values stated in SI units are to be regarded as the standard. The values given in parentheses are for information only.

1.4 *This standard does not purport to address all of the safety concerns, if any, associated with its use. It is the responsibility of the user of this standard to establish appropriate safety, health, and environmental practices and determine the applicability of regulatory limitations prior to use.* See also Section 9.

1.5 *This international standard was developed in accordance with internationally recognized principles on standardization established in the Decision on Principles for the*

*Development of International Standards, Guides and Recommendations issued by the World Trade Organization Technical Barriers to Trade (TBT) Committee.*

## 2. Referenced Documents

### 2.1 ASTM Standards:<sup>3</sup>

- D1193 Specification for Reagent Water
- D4080 Specification for Trichloroethylene, Technical and Vapor-Degreasing Grade
- G63 Guide for Evaluating Nonmetallic Materials for Oxygen Service
- G88 Guide for Designing Systems for Oxygen Service
- G93 Practice for Cleaning Methods and Cleanliness Levels for Material and Equipment Used in Oxygen-Enriched Environments
- G94 Guide for Evaluating Metals for Oxygen Service

### 2.2 Military Document:<sup>4</sup>

- MIL-D-16791 Detergent, General Purpose (Liquid, Non-ionic), Type One

### 2.3 American Chemical Society:<sup>5</sup>

- Trichloroethylene, Reagent Grade

### 2.4 Compressed Gas Association:<sup>6</sup>

- G-4 Oxygen
- G-4.1 Cleaning Equipment for Oxygen Service
- G-4.3 Oxygen, Gaseous, Type I B
- G-4.3 Oxygen, Liquid, Type II B
- G-10.1 Nitrogen, Gaseous, Type I B
- G-10.1 Nitrogen, Liquid, Type II B

<sup>1</sup> This test method is under the jurisdiction of ASTM Committee G04 on Compatibility and Sensitivity of Materials in Oxygen Enriched Atmospheres and is the direct responsibility of G04.01 on Test Methods.

Current edition approved Dec. 1, 2017. Published February 2018. Originally approved in 1984. Last previous edition approved in 2011 as G86 – 98a(2011). DOI: 10.1520/G0086-17.

<sup>2</sup> NASA Handbook 8060.1B, *Pressurized Liquid and Gaseous Oxygen Mechanical Impact Test*, Sept. 1981, pp. 4-72.

<sup>3</sup> For referenced ASTM standards, visit the ASTM website, [www.astm.org](http://www.astm.org), or contact ASTM Customer Service at [service@astm.org](mailto:service@astm.org). For *Annual Book of ASTM Standards* volume information, refer to the standard's Document Summary page on the ASTM website.

<sup>4</sup> Available from Standardization Documents Order Desk, DODSSP, Bldg. 4, Section D, 700 Robbins Ave., Philadelphia, PA 19111-5098, <http://dodssp.daps.dla.mil>.

<sup>5</sup> Available from American Chemical Society (ACS), 1155 Sixteenth Street, NW Washington, DC 20036, <http://www.acs.org>.

<sup>6</sup> Available from Compressed Gas Association (CGA), 4221 Walney Rd., 5th Floor, Chantilly, VA 20151-2923, <http://www.cganet.com>.

2.5 NASA Standard:<sup>7</sup>

NSS 1740.15 Safety Standard for Oxygen and Oxygen Systems

2.6 ASTM Adjuncts:

ABMA-Type Impact Tester and Anvil<sup>8</sup>

3. Terminology

3.1 Definitions of Terms Specific to This Standard:

3.1.1 *energy threshold, n*—the highest impact energy level at a given pressure for which the passing criteria have been met.

3.1.2 *GOX, n*—gaseous oxygen.

3.1.3 *LOX, n*—liquid oxygen.

3.1.4 *mechanical impact, n*—a blow delivered by a plummet that has been dropped from a pre-established height onto a striker pin in contact with a sample.

3.1.5 *reaction, n*—a chemical change or transformation in the sample initiated by a mechanical impact.

3.1.5.1 *Discussion*—A reaction from ambient pressure, LOX mechanical impact may be determined by an audible report, an electronically or visually detected flash, obvious charring of the sample, sample cup assembly, or striker pin.

3.1.5.2 *Discussion*—Reactions in pressurized LOX or GOX are typically indicated by an abrupt increase in test sample temperature, chamber pressure, and light levels and may be supplemented by obvious changes in odor, color, or material appearance as a result of thermal decompositions observed during examination after the test.

3.1.6 *pressure threshold, n*—the highest pressure at a given impact energy level for which the passing criteria have been met.

4. Summary of Test Method

4.1 The mechanical impact test system is designed to expose material samples to mechanical impact in the presence of liquid or gaseous oxygen at pressures from ambient to 68.9 MPa (0 to 10 000 psig). The basic test system configuration consists of: an electromagnet, a plummet, plummet guide tracks, plummet hold/release mechanism, base plate, anvil plate, a sample cup assembly holder, sample cup assembly, and striker pin (see Fig. 1). For tests conducted under pressure-controlled conditions, the anvil plate and sample cup assembly holder are replaced with a test chamber equipped with a striker pin or striker pin counterloader (see Fig. 2), test chamber purge, pressurization and vent systems (see Fig. 3), and a plummet catcher (see Fig. 4). The general procedure is to prepare the test sample and record significant pretest data.

4.2 *Ambient LOX Impact Test*—The test conditions (pressure and temperature) are the ambient pressure of the test facility and the boiling point of LOX at that pressure. Each sample is placed into a sample cup assembly (see Fig. 5, Fig.

<sup>7</sup> Available from National Aeronautics and Space Administration (NASA), NASA Headquarters, Suite 1M32, Washington, DC 20546.

<sup>8</sup> Detailed drawings from the ABMA-Type Impact Tester and Anvil Region Assembly are available at a nominal fee from ASTM International, 100 Barr Harbor Dr., Philadelphia, PA 19428. Request Adjunct ADJD2512.

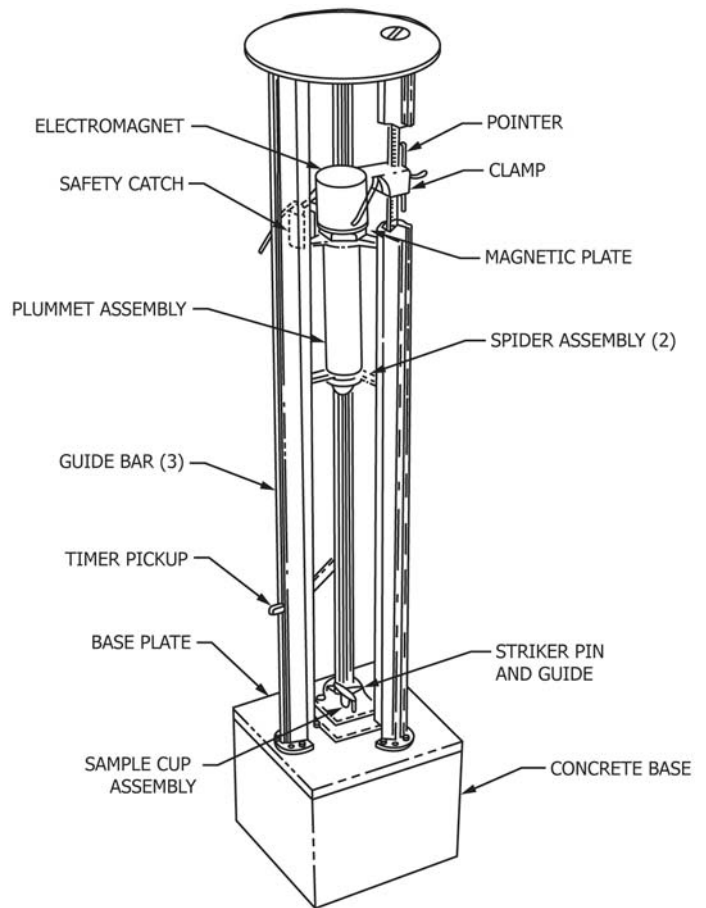
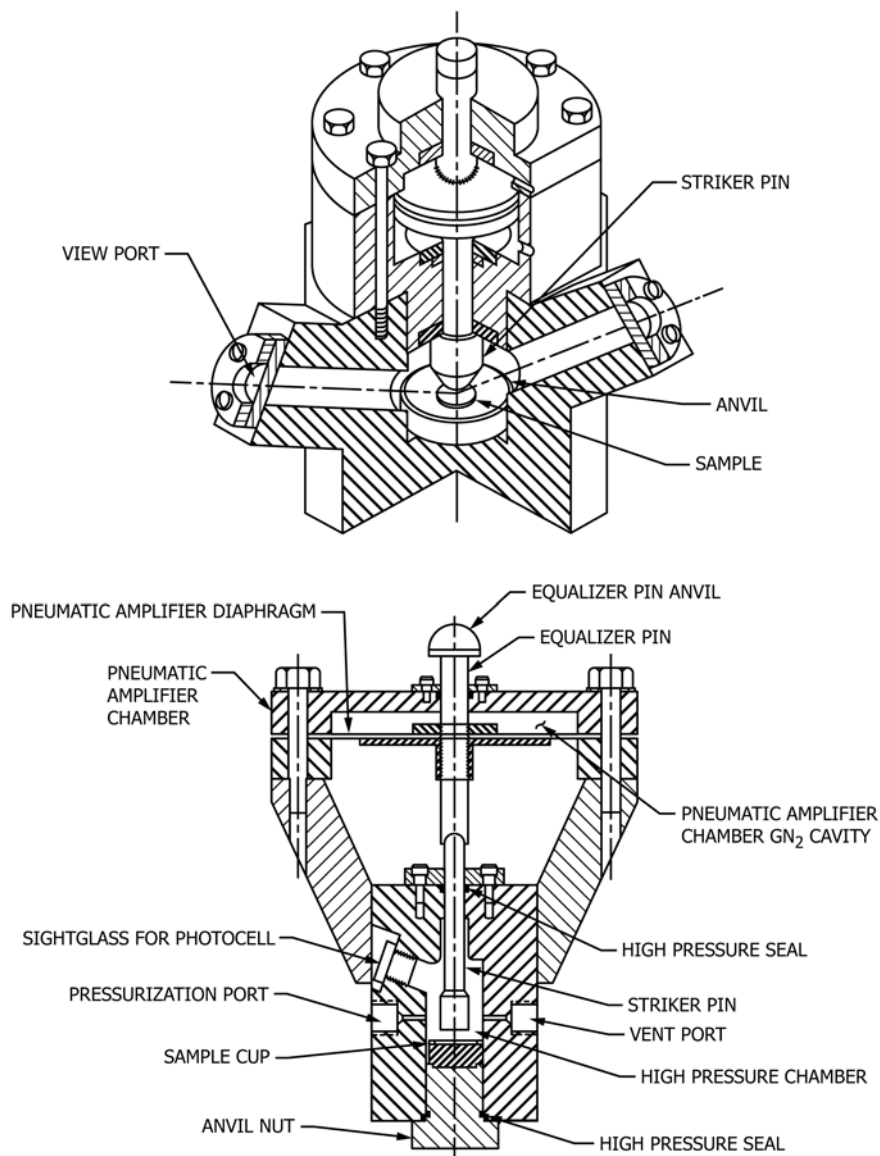

FIG. 1 Oxygen Impact Test Frame

11, and Fig. 14), precooled in a sample freezing box (Fig. 6), covered with LOX, and placed in the sample cup assembly holder seater in the anvil assembly of the impact tester. The plummet is dropped from a selected height onto the striker pin, which transmits the energy to the test sample. Observation for any reaction is made and noted. Drop tests are continued using a fresh sample, sample cup assembly, and striker pin for each drop until the threshold level is determined or the test series is completed.

NOTE 1—When testing samples that are sometimes capable of initiating false reactions with the aluminum cups, use stainless steel disks as false bottoms in the cups. To minimize interaction, insert disks should be used between abrasive samples and one-piece cups, or sample cup assemblies/holders with a steel base (Fig. 11 and Fig. 14) should be used in place of aluminum one-piece cups.

4.3 For materials tested in pressurized LOX or GOX, each sample is placed in the test chamber. The test chamber is filled with liquid or gaseous oxygen, pressurized to the required test pressure, and the striker pin or striker pin counterloader is pressed down against the top of the test sample. The plummet is dropped from a selected height onto the striker pin or striker pin counterloader. Instrumentation devices that monitor the test chamber interior for pressure, temperature, and light emission provide evidence of test sample reaction. The sample is removed from the chamber, and the sample is inspected for other evidence of reaction such as odor or charring. Drop tests



1	Pneumatic Amplifier Chamber	9	High-Pressure Chamber
2	Equalizer Pin Anvil	10	Sample Cup Assembly
3	Equalizer Pin	11	Anvil Nut
4	Pneumatic Amplifier Diaphragm	12	High-Pressure Seal
5	Pneumatic Amplifier Chamber GN <sub>2</sub> Cavity	13	Pressurization Port
6 and 8	Striker Pin	14	Vent Port
7	High-Pressure Seal	15	Sightglass for Photocell

**FIG. 2 Two Types of High-Pressure Test Chambers**

are continued using a fresh sample, sample holder, and striker pin or striker pin counterloader for each drop, until the threshold level is determined or the test series is completed. Additional modifications to the above procedure are required when testing is performed at temperatures above ambient.

4.4 This test method may be used to determine the impact sensitivity of a material, batch-to-batch acceptance, or to satisfy other prescribed pass-fail criteria.